



USER MANUAL



MEGP 25 ELECTRIC GRIPPER (FOR MECA500 R3)

DOCUMENT VERSION: 1.1

August 28, 2018

The information contained herein is the property of Mecademic Inc. and shall not be reproduced in whole or in part without prior written approval of Mecademic Inc. The information herein is subject to change without notice and should not be construed as a commitment by Mecademic Inc. This manual will be periodically reviewed and revised.

Mecademic Inc. assumes no responsibility for any errors or omissions in this document.

Copyright © 2018 by Mecademic Inc.

Contents

1	Introduction	1
2	Warning messages, notes and emphasis	1
3	What's inside the box	2
4	Design and mounting of the fingers	2
5	Installing the gripper	4
6	Operating the MEGP 25 gripper	7
7	Safety	7

This page is intentionally left blank

1 Introduction

This user manual describes how to install the MEGP 25 electric gripper onto the Meca500 (R3) industrial robot arm. You must read this manual thoroughly before installing or operating the MEGP 25 electric gripper. You must, however, first read the [User Manual](#) of the Meca500 (R3).

The MEGP 25 gripper is a parallel gripper developed by Mecademic and Schunk, specifically for the Meca500 robot arm. Improper installation of this gripper could seriously damage the Meca500 and the gripper itself. This gripper should therefore be used only by technical personnel who are familiar with the Meca500.

2 Warning messages, notes and emphasis

Particular attention must be paid to the warning messages in this manual. There are only two types of warning messages, as shown below:

**WARNING:**

This presents instructions that must be followed in order to prevent injuries and possibly damage to your robot cell (gripper, robot arm, power supply, workpiece and/or adjacent equipment).

**CAUTION:**

This presents instructions that must be followed in order to prevent damage to your robot cell (gripper, robot arm, power supply, workpiece and/or adjacent equipment).

In addition, important notes and definitions are formatted as follows:

**NOTICE:**

This highlights important suggestions or definitions, the purpose of which is to improve the understanding of this manual and of how the robot works.

Finally, occasionally, small portions of the text in this manual that are particularly important are underlined (as already done in the previous section).

3 What's inside the box

Your MEGP 25 gripper was supplied either individually or with the Meca500. In both cases, the gripper is delivered as a standard kit in an anti-static bag, the contents of which is:

- 1 MEGP 25 gripper with a cable attached;
- 1 adaptor plate for attaching the gripper to the Meca500's mechanical interface;
- 4 M3X0.5 Torx flat head screws of length 8 mm;
- 2 M2.5X0.45 socket head screws of length 20 mm.

Note that Mecademic does not supply any fingers. You must design and machine these based on the workpiece that needs to be handled.

4 Design and mounting of the fingers

Before mounting the MEGP 25 on your Meca500, you need to design and mount the fingers. If you are unfamiliar with grippers, the following two textbooks will be particularly useful:

- [1] A. Wolf, R. Steinmann, H. Schunk, *Grippers in Motion: The Fascination of Automated Handling Tasks*, Springer, 2005.
- [2] G.J. Monkman, S. Hesse, R. Steinmann, H. Schunk, *Robot Grippers*, Wiley-VCH, 2006.

Figure 1 shows the dimensions of the MEGP 25 and the adaptor plate provided. Each finger must be attached to the outer side of a gripper jaw through an M4X0.7 screw and two $\varnothing 1.5$ locating pins. The maximum dimensions of the fingers and the maximum permissible loads on the jaws of the gripper are shown in Fig. 2. Finally, Table 1 lists the technical specifications for the gripper, which must be taken into account when designing the fingers.

Operating data	Value
Stroke per jaw	3 mm
Maximum admissible weight per finger	0.02 kg
Maximum gripping force	40 N
Repeatability	0.02 mm
Recommended workpiece weight	0.2 kg
Gripper weight	0.150 kg
Protection class IP	30

Table 1: Technical specifications for the MEGP 25 gripper

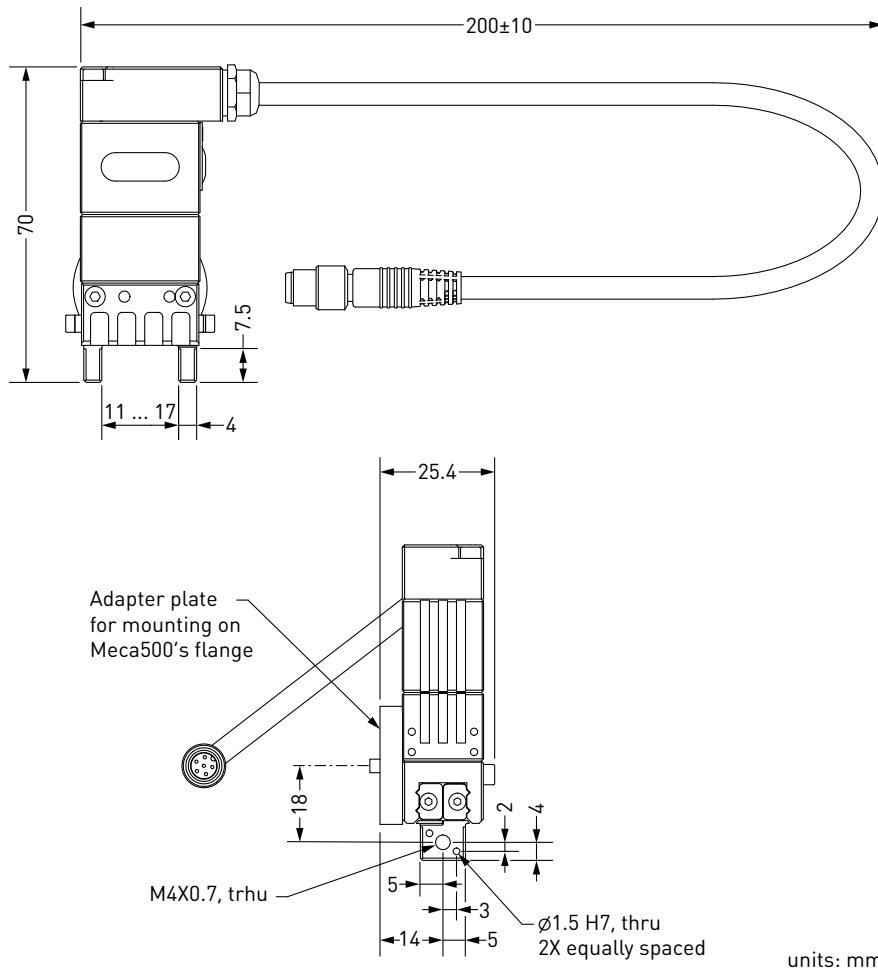

Figure 1: Dimensions of the MEGP 25 gripper

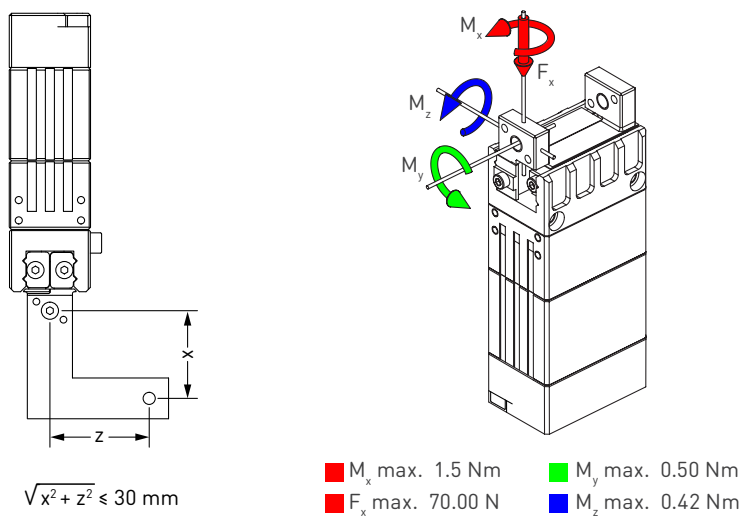

Figure 2: Maximum permissible finger dimensions and finger loads

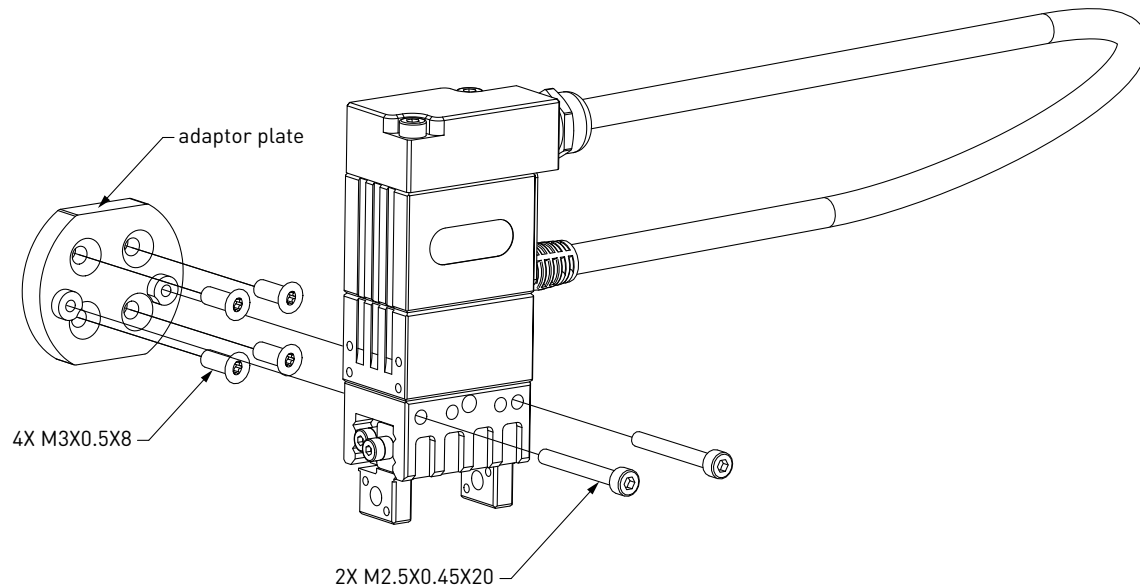

Figure 3: Mounting the MEGP 25 gripper to the flange of the Meca500

5 Installing the gripper

The MEGP 25 electric gripper is designed and supplied with an assembly kit for only one type of installation (Figs. 3 and 4). If you want to mount the gripper on the flange of the Meca500 in a different way, you need to design and machine your own adaptor plate. Note, however, that if you use a different adaptor plate or if you do not install your gripper in exactly the same manner as shown in Figs. 3 and 4, it is quite possible that the gripper cable will be too short. Therefore, an installation other than the one shown here may limit the range of motion of joint 6 and may result in damage to the gripper and/or the robot.

Before installing the gripper, turn the robot on and bring all joints to zero degrees. If the screw on the flange of the robot is not as in Fig. 4a, follow the procedure explained in Section 2.2.1 of the [Programming Manual](#) of the Meca500 (R3).



WARNING:

Before installing the MEGP 25 gripper on the Meca500, make sure that the robot is unpowered and that joint 6 is at zero degrees.

To install the gripper, switch off the robot, refer to Figs. 3 and 4, and follow these steps:

1. Remove the screw cap from the I/O tool port (Fig. 4a) and store it for future use.
2. Make sure that you did zero joint 6 prior to powering off the robot and that the screw on the flange of the robot is as shown in Fig. 4a.

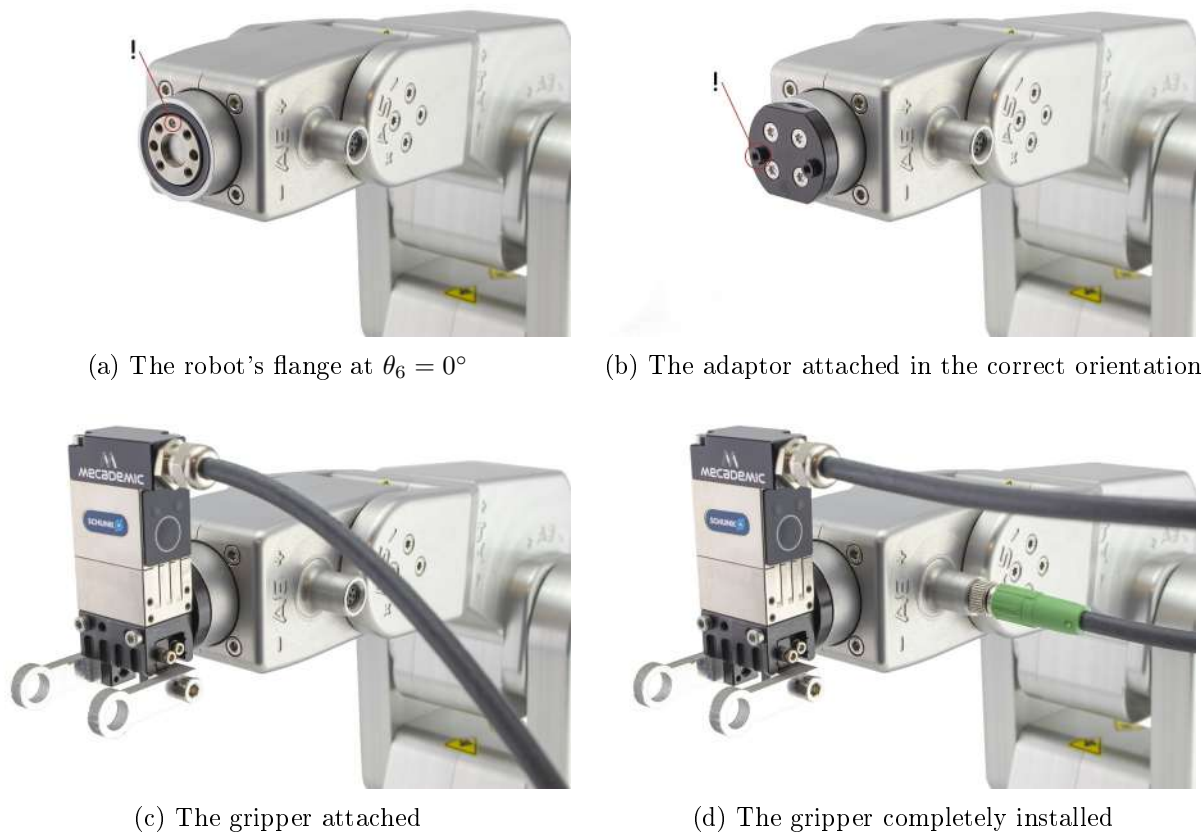

Figure 4: Installing Mecademic's MEGP 25 gripper

3. Attach the adaptor plate in the exact orientation shown in Fig. 4b (there is another possible—but incorrect—orientation) using the four M3X0.5X8 Torx flat head screws provided. Do not use any other screws. Using longer screws will damage joint 6.
4. Attach the gripper exactly as shown in Figs. 3 and 4c using the two M2.5X0.45X20 socket head screws provided.
5. Finally, attach the connector of the gripper to the I/O tool port of the robot, as shown in Fig. 4c. It is very important that the robot be unpowered during this operation.



WARNING:

The MEGP 25 gripper is not “hot-pluggable”. You should never screw or un-screw its cable while the robot is powered. Otherwise you may damage both the robot and the gripper.



Figure 5: The MEGP 25 completely installed and homed

Once the gripper is completely installed, you can start using your robot. When the Meca500 is activated, it will automatically detect the gripper, and the red LED on the gripper will be illuminated and will stay so as long as the gripper is active.

Finally, when the robot is homed, the gripper will also be homed at the very end, fully opening its fingers and then fully closing them. This homing procedure is necessary in order to detect the range of motion of the fingers, in case their design reduces the nominal 6-mm range. Once the gripper is homed, the green LED on the gripper will be illuminated (Fig. 5) and will stay so as long as the gripper is active.



CAUTION:

When the robot is deactivated, the fingers of the gripper exert no force. Furthermore, during homing of the robot, the fingers open and close. Therefore, never leave a workpiece in the gripper when activating or deactivating your Meca500.

6 Operating the MEGP 25 gripper

The MEGP 25 gripper is operated within the same stream of commands used to operate the Meca500. Using Ethernet TCP/IP, it can be closed and opened with the GripperOpen and GripperClose commands, respectively. In addition, you can set gripping force with the SetGripperForce(f) command, where f is ranging from 0 to 100% (i.e., from 0 to approximately 40 N). By default, the grip force limit is 50%. Finally, you can also set the gripping velocity with the SetGripperVel(v) command, where v is the finger velocity limit, ranging from 1% to 100% (approximately 95 mm/s). By default, the finger velocity limit is 50%.

Note, that there is a button on the gripper, right bellow the two LEDs (Fig. 5). This button is currently not operational. It will be used for manually opening and closing the gripper in the near future.

Finally, note that if you keep your gripper closed or opened for a relatively long time, while holding a piece (i.e., while not at one of the gripper extremities detected during homing), the gripper will become very hot. This is perfectly normal.

7 Safety

While the MEGP 25 gripper itself is safe by design, the fingers that you mount on it and the workpieces that you manipulate with it may lead to potential risks for injuries. For example, if the fingers or workpiece have cutting edges, there is a risk for cutting. Also, if your gripping force is too low and the gripper moves with high accelerations, the workpiece manipulated may get ejected.

**WARNING:**

You must perform a thorough risk assessment of your complete robot cell to determine the necessary precautions that must be taken in order to assure a safe operation.



Mecademic Inc.
1300 Saint-Patrick St
Montreal QC H3K 1A4
CANADA